



Rotary table cylinder—HRQ Series

Compendium of HRQ Series

Higher manufacturing precision of working platform

The manufacturing precision of working platform is high, and is easy for installation, and is of precise orientation.
The center of working platform has a through hole, and pipe can be located and passed through this hole;

Double cylinder structure

Double cylinder structure, double output could be achieved.

Rack and pinion design

Rack and pinion design, stable functioning.

With magnetic switch slots

Three kinds of type could be chosen

Mini-sized Rotary Cylinder: 2、3、7
Middle-sized Rotary Cylinder: 10、20、30、50
Large-sized Rotary Cylinder: 70、100、200

Simply to install

Guide hole is designed on the both side of the cylinder body (10~200) or undersurface (2~7), which is simply to install.

Two modes of buffer could be chosen

Adjustment bolt buffer and internal shock absorber could be chosen



Installation and application

1. Dirty substances in the pipe must be eliminated before cylinder is connected with pipeline to prevent the entrance of impurities into the cylinder.
2. The medium used by cylinder shall be filtered to 40μm or below.
3. Anti-freezing measure shall be adopted under low temperature environment to prevent moisture freezing.
4. If the cylinder is dismantled and stored for a long time, pay attention to conduct anti-rust treatment to the surface. Anti-dust caps shall be added in air inlet and outlet ports.

Maximum allowed loading

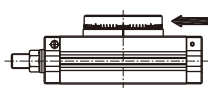
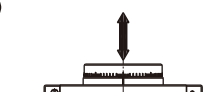
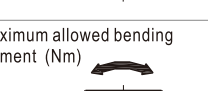
Loading type	Model									
	HRQ2	HRQ3	HRQ7	HRQ10	HRQ20	HRQ30	HRQ50	HRQ70	HRQ100	HRQ200
Maximum allowed radial loading (N) 	18	30	50	80	150	200	300	330	390	540
Maximum allowed axial loading (N) 	35	50	70	80	150	200	300	300	500	740
Maximum allowed bending moment (Nm) 	0.8	1.1	1.5	2.5	4.0	5.5	10.0	12.0	18.0	25.0

Actual torque output

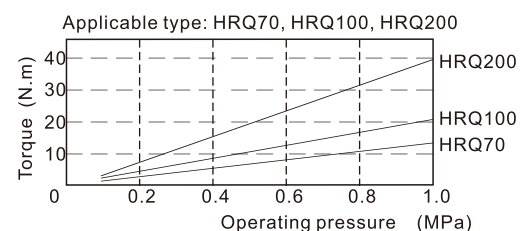
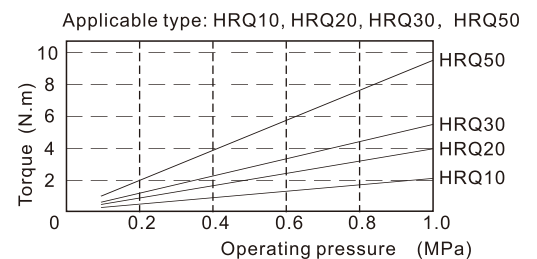
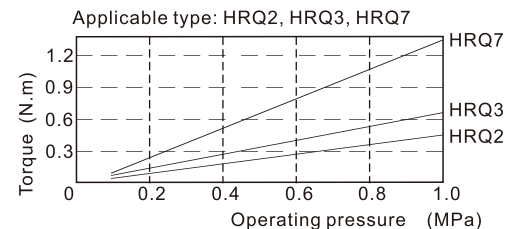

Rotary table cylinder

HRQ Series



Symbol

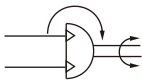

Product feature

1. Rack and pinion design, stable functioning.
2. Double cylinder structure, double output could be achieved.
3. The manufacturing precision of working platform is high, and is easy for installation, and is of precise orientation.
4. The center of working platform has a through hole, and pipe can be located and passed through this hole;
5. Guide hole is designed on the both side of the cylinder body (10~200) or undersurface (2~7), which is simply to install.
6. Two modes of buffer could be chosen, adjustment bolt buffer and internal shock absorber, the maximum buffer energy of internal shock absorber is 3-5 times that of adjustment bolt buffer.

Specification

Specification	2	3	7	10	20	30	50	70	100	200
Acting type	Double rack and pinion(Double acting)									
Fluid	Air(to be filtered by 40μm filter element)									
Operating pressure	With adjustment bolt									
	With internal shock absorber									
Proof pressure	1.2MPa(175psi)(12.0bar)									
Temperature °C	-20~70									
Angle adjustment range	0~190°									
Repeatable precision	With adjustment bolt									
	With internal shock absorber									
Theoretic moment (Nm)(0.5MPa)	0.2	0.33	0.63	1.1	2.2	2.8	5.0	7.5	11.0	22.0
Cushion type	With adjustment bolt									
	With internal shock absorber									
Port size	End ports									
	Side ports									
	Weight g									

[Note1] G thread is available.

Add) Refer to P519 for detail of sensor switch.

Maximum allowed movement energy and rotation times

Model	Maximal allowed energy (J)		Rotation times (s/90°)	
	With adjustment bolt	With internal shock absorber	With adjustment bolt	With internal shock absorber
HRQ2	0.0015	-	0.2~0.7	-
HRQ3	0.002	-	0.2~0.7	-
HRQ7	0.006	-	0.2~1.0	-
HRQ10	0.01	0.04	0.2~1.0	0.2~0.7
HRQ20	0.025	0.12	0.2~1.0	0.2~0.7
HRQ30	0.05	0.12	0.2~1.0	0.2~0.7
HRQ50	0.08	0.30	0.2~1.0	0.2~0.7
HRQ70	0.24	1.1	0.2~1.5	0.2~1.0
HRQ100	0.32	1.6	0.2~2.0	0.2~1.0
HRQ200	0.56	2.9	0.2~2.5	0.2~1.0

[Note]

1: The movement energy should not exceed the allowed maximum energy, or the inner accessories of product would be damaged;

2: When the rotation times of with shock absorber is larger than the allowed tolerance, the bigger effect will be lost.

Ordering code

HRQ 20 A G



① Model	② Specification	③ Cushion type	④ Thread type
HRQ: Rotary Table/Rack & Pinion Style	2	Blank: With adjustment bolt	No this code
	3		
	7		
	10	Blank: With adjustment bolt A: With internal shock absorber	G: G
	20		
	30		
	50		
	70		
	100		
200			

[Note] HRQ series are all attached with magnet.

Rotary table cylinder

HRQ Series

HRQ10~50

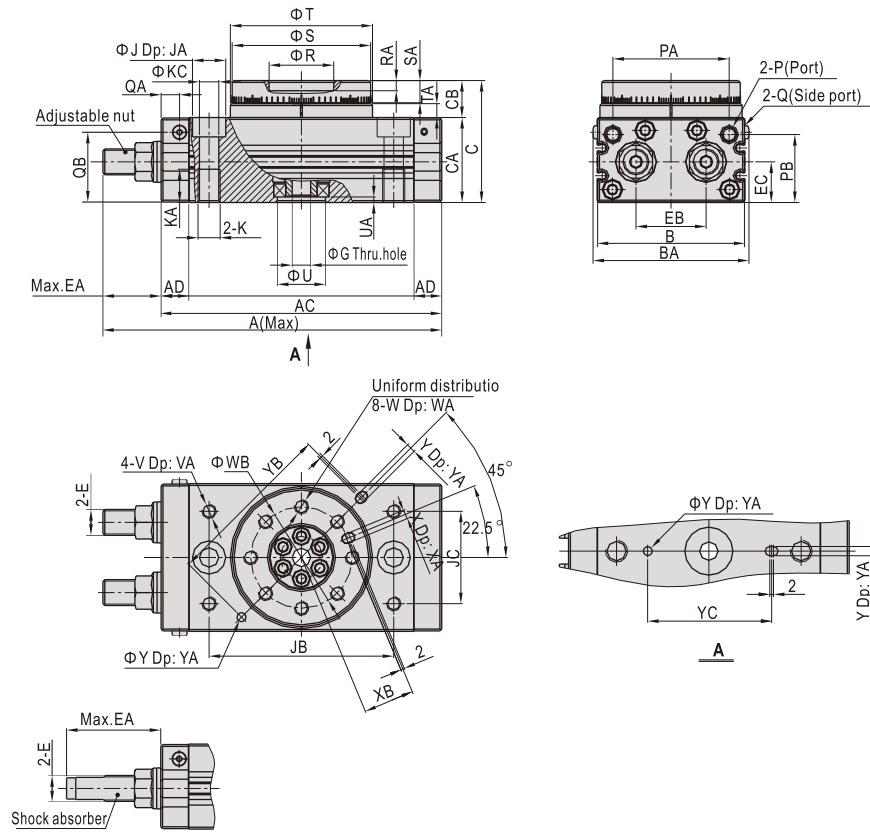

HRQ□-A(With internal shock absorber)

Type\Item	A(With internal shock absorber)	A(With adjustment bolt)	AC	AD	B	BA	C	CA	CB	E	EA(With internal shock absorber)	EA(With adjustment bolt)
10	123	112	92	9.5	50	54	47	34	13	M10×1.0	31	20
20	169	145.3	117	11	65	69	54	37	17	M12×1.0	52	28.3
30	178.5	154.5	127	11.5	70	74	57	40	17	M12×1.0	51.5	27.5
50	212	185.9	152	15	80	84	66	46	20	M14×1.5	60	33.9

Type\Item	EB	EC	G	J	JA	JB	JC	K	KA	KC	P	PA	PB	Q	QA	QB	R	RA	S	SA
10	20.5	14	5	11	6.5	60	27	M8×1.25	12	6.5	M5×0.8	34.5	28	M5×0.8	4.5	29	20(H9)	4.5	45(h9)	8
20	27.5	16	9	14	8.5	76	34	M10×1.5	15	8.5	M5×0.8	47	30	M5×0.8	6	30	28(H9)	6.5	60(h9)	10
30	29	18.5	9	14	8.5	84	37	M10×1.5	15	8.5	1/8"	50	32	M5×0.8	6.5	34	32(H9)	5	65(h9)	10
50	38	22	10	18	10.5	100	50	M12×1.75	18	10.5	1/8"	63	38	M5×0.8	10	38	35(H9)	5.5	75(h9)	12

Type\Item	T	TA	U	UA	V	VA	W	WA	WB	X	XA	XB	Y	YA	YB	YC
10	46(h9)	4.5	15(H9)	3	M5×0.8	8	M5×0.8	8	32	3(H9)	3.5	16	3(H9)	3.5	56	40
20	61(h9)	6.5	17(H9)	2.5	M6×1.0	8	M6×1.0	10	43	4(H9)	4.5	21.5	4(H9)	4.5	74	50
30	67(h9)	6.5	22(H9)	3	M6×1.0	8	M6×1.0	10	48	4(H9)	5	24	4(H9)	4.5	80	58
50	77(h9)	7.5	26(H9)	3	M8×1.25	8	M8×1.25	12	55	5(H9)	6	27.5	5(H9)	5.5	92	68

Rotary table cylinder

HRQ Series

HRQ70~200

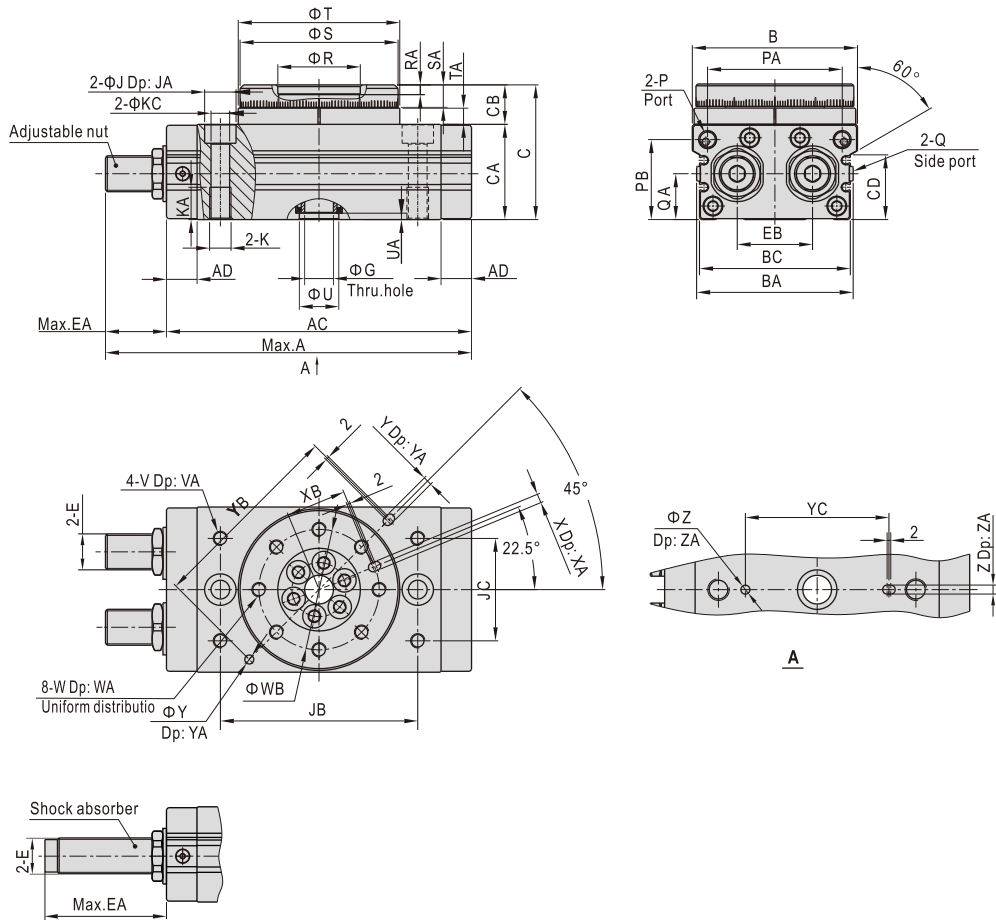

HRQ□-A(With internal shock absorber)

Type\Item	A(With adjustment bolt)	A(With internal shock absorber)	AC	AD	B	BA	BC	C	CA	CB	CD	E	EA(With adjustment bolt)						
70	206.8	244	170	17	92	88	84	75	53	22	36	M20×1.5	36.8						
100	225.7	263	189	17	102	99	95	86	59	27	42	M20×1.5	36.7						
200	279.5	316.5	240	24	120	117	113	106	74	32	57	M27×1.5	39.5						
Type\Item	EA(With internal shock absorber)	EB	G	J	JA	JB	JC	K	KA	KC	P	PA	PB	Q	QA	R	RA	S	SA
70	74	42	16	17.5	12	110	57	M12×1.75	18	10.5	1/8"	75	44	M5×0.8	25	46(H9)	5	88(h9)	12.5
100	74	50	19	17.5	12	130	66	M12×1.75	18	10.5	1/8"	85	50	M5×0.8	29	56(H9)	6	98(h9)	14.5
200	76.5	60	24	20	12.5	150	80	M16×2.0	25	14	1/8"	103	62.5	M5×0.8	36	64(H9)	9	116(h9)	16.5
Type\Item	T	TA	U	UA	V	VA	W	WA	WB	X	XA	XB	Y	YA	YB	YC	Z	ZA	
70	90(h9)	9	22(H9)	3.5	M8×1.25	10	M8×1.25	12.5	67	5(H9)	5.5	33.5	5(H9)	3.5	110	80	5(H9)	3.5	
100	100(h9)	12	24(H9)	3.5	M8×1.25	10	M10×1.5	14.5	77	6(H9)	6.5	38.5	6(H9)	4.5	120	100	6(H9)	4.5	
200	118(h9)	15	32(H9)	5.5	M12×1.75	13	M12×1.75	16.5	90	8(H9)	8.5	45	8(H9)	4.5	140	110	8(H9)	6.5	

HRQ Series

How to select product

- Determine the following working conditions according to the actual situation:
 - Rotation angle θ : The actual rotation angle must be within the maximum allowed range of rotation angle of cylinder.
 - Rotation time t : The rotation time must be within the maximum allowed range of rotation time of cylinder.
 - Installation position of cylinder: Allow enough installation space, so as to ensure leaving adequate space for rotation of cylinder and workpieces.
 - Determination of loading mass and loading shape.

$$T = K \times I \times \dot{\omega}$$

$$\dot{\omega} = \frac{2\theta}{t^2}$$

T : Necessary torque required for loading rotation (N.m)
 K : Coefficient of allowance, K is defined as 5
 I : Moment of inertia (kg.m²)
 $\dot{\omega}$: Angular acceleration (rad/s²)
 θ : Rotation Angle (rad)
 t : Rotation time (s)

2. Calculation of necessary torque needed when loading rotation (T(N.m)):

Calculate the necessary moment required for loading rotation according to the formula below, and combine with the torque diagram of actual effect, to choose pneumatic cylinder with suitable torque output.

2.1) Calculation method of moment of inertia in different conditions

Diagram	Description	Calculation formula of moment of inertia	Rotation radius	Diagram	Description	Calculation formula of moment of inertia	Rotation radius
	d: Diameter (m) m: Mass (kg)	$I = \frac{md^2}{8}$	$\frac{d^2}{8}$		a: Sheet length (m) b: Length of side (m) m: Mass (kg)	$I = \frac{m(a^2+b^2)}{12}$	$\frac{a^2+b^2}{12}$
		Note: no special installation direction				Note: no special installation direction	
	d ₁ : Diameter (m) d ₂ : Diameter (m) m ₁ : d ₁ Mass (kg) m ₂ : d ₂ Mass (kg)	$I = \frac{m_1 d_1^2 + m_2 d_2^2}{8}$	$\frac{d_1^2 + d_2^2}{8}$		a: Sheet length (m) m: Mass (kg)	$I = \frac{ma^2}{12}$	$\frac{a^2}{12}$
		Note: compare d ₁ with d ₂ , disregard d ₁ if d ₁ is extremely tiny				Note: no special installation direction	
	d: Diameter (m) m: Mass (kg)	$I = \frac{md^2}{16}$	$\frac{d^2}{16}$		a: Sheet length (m) m: Mass (kg)	$I = \frac{ma^2}{3}$	$\frac{a^2}{3}$
		Note: no special installation direction				Note: 1. horizontal installation. 2. pay attention to the change of movement time when vertical installation.	
	r: Radius (m) m: Mass (kg)	$I = \frac{2mr^2}{5}$	$\frac{2r^2}{5}$		a: Sheet length (m) b: Distance between the rotation axis and the gravity center of loading (m) m: Mass (kg)	$I = \frac{ma^2}{12} + mb^2$	$\frac{a^2}{12} + b^2$
		Note: no special installation direction				Note: the cuboids are same too.	
	a ₁ : Length of stick (m) a ₂ : Length of stick (m) m ₁ : a ₁ Mass (kg) m ₂ : a ₂ Mass (kg)	$I = \frac{m_1 a_1^2 + m_2 a_2^2}{3}$	$\frac{a_1^2 + a_2^2}{3}$		a: Tooth number of gear b: Tooth number of loading gear	$I_a = \left(\frac{a}{b}\right)^2 I_b$	
		Note: 1. horizontal installation. 2. pay attention to the change of movement time when vertical installation.					
	a ₁ : Sheet length (m) a ₂ : Sheet length (m) b: Length of side (m) m ₁ : a ₁ Mass (kg) m ₂ : a ₂ Mass (kg)	$I = \frac{m_1(4a_1^2+b^2) + m_2(4a_2^2+b^2)}{12}$	$\frac{2a_1^2 + 2a_2^2 + b^2}{6}$		a ₁ : Vertical distance between the rotation axis and the concentrated loading (m) a ₂ : Length of arm (m) m ₁ : Mass of concentrated loading (kg) m ₂ : Mass of arm (kg)	$I = m_1 a_1^2 + \frac{m_2 a_2^2}{3} + m_2 K$	
		Note: 1. horizontal installation. 2. pay attention to the change of movement time when vertical installation.				Note: 1. horizontal installation. 2. compared with m, disregard if m is extremely tiny. 3. calculate K according to the shape of concentrated loading row by row. For example, when the loading is spheroid, $K = 2r^2/5$	

3. Calculation of maximum movement energy E_{max} (J):

Calculate the maximum movement energy E_{max} according to the formula below, and make sure that the maximum movement energy is within allowed energy range of the chosen pneumatic cylinder, excessive large movement energy would lead to damage of inner parts, please choose rotation cylinder attached with shock absorber when the movement energy is fairly large.

$$E_{\max} = \frac{1}{2} I \omega_{\max}^2 \quad \omega_{\max} = \frac{2\theta}{t} \quad \omega_{\max}: \text{Maximal angular velocity (rad/s)}$$

4. Calculation of loading rate

Calculate the loading rate according to the formula below, and the loading rate must not be more than 1.

$$\text{Loading rate} = \frac{W_s}{\text{Maximal allowed axial loading}} + \frac{W_r}{\text{Maximal allowed radial loading}} + \frac{M}{\text{Maximal allowed bending moment of working platform}} \leq 1$$

W_s : Actual axial loading W_r : Actual radial loading M : Actual loaded bending moment of working platform

5. Determination method

It could be used only when the chosen pneumatic cylinder must meet the requirements of article 2, 3 and 4 simultaneously.

HRQ Series

Installation and application

1. Rotation Direction and Rotation Angle

1.1) Rotation Direction

HRQ2/3/7

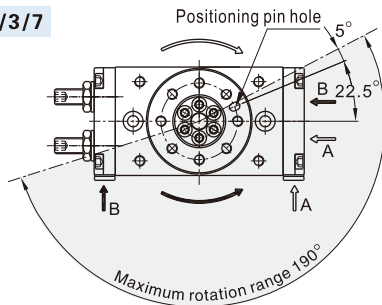

HRQ10~200

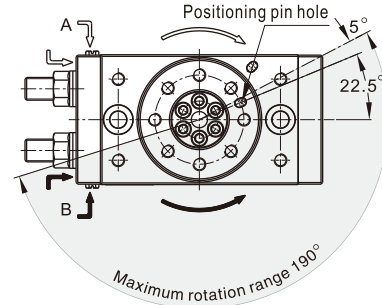

A) By adjusting the adjustment bolt, the rotation end can be set within the range shown in the up drawing: Maximum rotation is 190° ;
 B) The rotary table turns in the clockwise direction when the A port is pressurized, and in the counter-clockwise direction when the B port is pressurized.

1.2) Rotation Range Example(90° Rotation)

HRQ2/3/7

Adjustment amount by adjustment bolt B

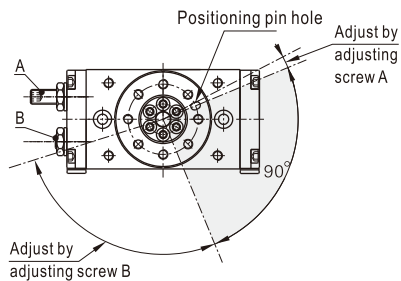

HRQ10~200

Adjustment amount by adjustment bolt B

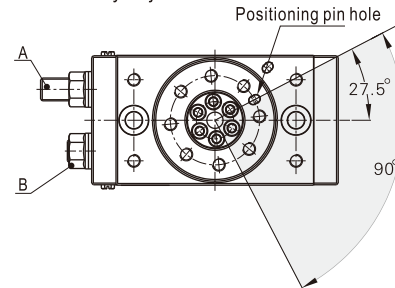

Adjustment amount by adjustment bolt A

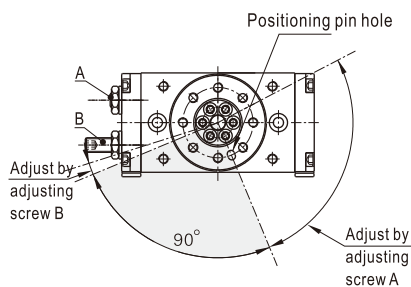

Adjustment amount by adjustment bolt A

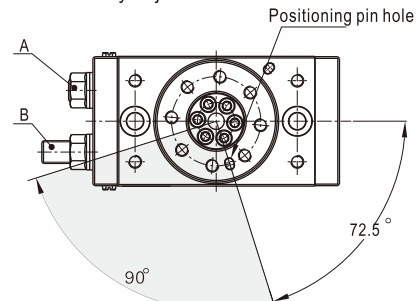

Adjustment amount by adjustment bolt A, B

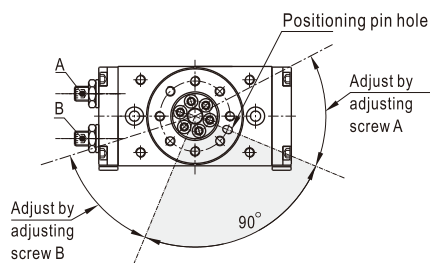

Adjustment amount by adjustment bolt A, B

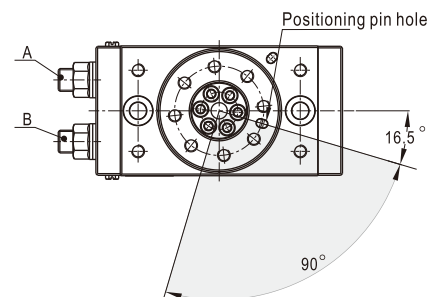

1.3) The rotation angle can also be set on a type with internal absorber.

Model	Adjustment angle per rotation of angle(adjustment screw)	Model	Adjustment angle per rotation of angle(adjustment screw or shock absorber)
HRQ2	11.5°	HRQ10	10.2°
HRQ3	10.9°	HRQ20	6.5°
HRQ7	10.2°	HRQ30	6.5°
		HRQ50	8.2°
		HRQ70	7.0°
		HRQ100	6.1°
		HRQ200	4.9°

HRQ Series

2. The range of rotation angle has been adjusted to the maximum in the factory, please do not enlarge the rotation angle any more.
3. The movement energy should not exceed the allowed maximum energy, or the inner parts will be damaged.
4. The rotary parts need no lubrication.
5. Series HRQ is equipped with a rubber bumper or shock absorber. Therefore, perform rotation adjustment in the pressurized condition (minimum operation pressure: 0.1 Mpa or more for adjustment bolt and internal shock absorber types, and 0.2 MPa or more for external shock absorber type.)
6. Refer to the table below for tightening torques of the shock absorber setting nut.

Shock absorber size	Max. tightening torque(Nm)
M10	3.5
M12	8.0
M14	11.0
M20	24.0
M27	63.0

7. Never loosen the bottom screw of the shock absorber. (It is not an adjustment screw.) That may cause oil leakage.
8. Shock absorbers are consumable parts.
When a decrease in energy absorption capacity is noticed, it must be replaced.

Rotary table cylinder	Shock absorber
HRQ10	ACA1006-A
HRQ20\HRQ30	ACA1215-A
HRQ50	ACA1416-A
HRQ70\HRQ100	ACA2020-A
HRQ200	ACA2725-A

9. Strictly control run out and parallelism of the dial according to the requirements of the following table.

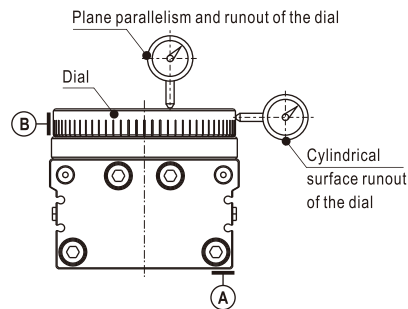

Items	Specific requirements	Relative datum
Plane parallelism of the dial	0.1	A
Plane runout of the dial	0.1	A
Cylindrical surface runout of the dial	0.1	A