



Twin-rod cylinder—TR Series

Compendium of TR Series

JIS standard

Five or six bore size are available
Bore size: 6, 10, 16, 20, 25, 32

Bumper in front of the barrel
Bumper in front of the barrel can adjust the stroke of cylinder and relieve impact.

Twin-rod cylinder
It is good resistance to bending and twisting moments.

Be mounted the workpiece from three directions

Be mounted cylinder from four directions

Magnetic switch slots around the cylinder body
There are magnetic switch slots around the cylinder body convenient to install inducting switch.

Criteria for selection: Cylinder thrust

Unit: Newton(N)

Bore size	Rod size	Acting type		Pressure area(mm ²)	Operating pressure(MPa)						
					0.1	0.2	0.3	0.4	0.5	0.6	0.7
6	4	Double acting	Push side	56.5	5.7	113.	17.0	22.6	28.3	33.9	39.6
			Pull side	31.4	3.1	6.3	9.4	12.6	15.7	18.8	22.0
10	6	Double acting	Push side	157.1	15.7	31.4	47.1	62.8	78.6	94.3	110.0
			Pull side	100.5	10.1	20.1	30.2	40.2	50.3	60.3	70.4
16	8	Double acting	Push side	402.1	40.2	80.4	120.6	160.8	201.1	241.3	281.5
			Pull side	301.6	30.2	60.3	90.5	120.6	150.8	181.0	211.1
20	10	Double acting	Push side	628.3	62.8	125.7	188.5	251.3	314.2	377.0	439.8
			Pull side	471.2	47.1	94.2	141.4	188.5	235.6	282.7	329.8
25	12	Double acting	Push side	981.7	98.2	196.4	294.5	392.7	490.9	589.0	687.2
			Pull side	755.6	75.6	151.1	226.7	302.2	377.8	453.4	528.9
32	16	Double acting	Push side	1608.5	160.9	321.7	482.6	643.4	804.3	965.1	1126.0
			Pull side	1206.4	120.6	241.3	361.9	482.6	603.2	723.8	844.5

Installation and application



- When load changes in the work, the cylinder with abundant output capacity shall be selected.
- Relative cylinder with high temperature resistance or corrosion resistance shall be chosen under the condition of high temperature or corrosion;
- Necessary protection measure shall be taken in the environment with higher humidity, much dust or water drops, oil dust and welding dregs.
- Dirty substances in the pipe must be eliminated before cylinder is connected with pipeline to prevent the entrance of particles into the cylinder;
- The medium used by cylinder shall be filtered to 40μm or below.
- As both the front cover and piston are short, too large stroke can not be selected.
- Anti-freezing measure shall be adopted under low temperature environment to prevent moisture freezing.
- The cylinder shall avoid radial load in operation to maintain the normal and extend service life.
- If the cylinder is dismantled and stored for a long time, please conduct anti-rust treatment to the surface. Anti-dust cap shall be inserted into the inlet and outlet ports. As the precision of the manufacture and guide is high, Please do not dismantle the fixed block or cylinder cover .



Twin-rod cylinder

TR Series



Symbol



Product feature

1. JIS standard is implemented.
2. The non-rotating precision is high and deflection of the end of piston rod is low, which is suitable for precise guide.
3. It adopts lengthening type sliding supporting guide. No additional lubricant is needed and it has good performance of guide.
4. Mounting holes on three sides facilitates multi-position mounting.
5. It is good resistance to bending and twisting moments.
6. Except for the axial, each side of the cylinder has installation orifices to provide several installation and fixation ways for the customers.
7. There are two groups of air intake and outlet at two sides of the cylinder for the actual selection.
8. Bumper in front of the barrel can adjust the stroke of cylinder and relieve impact.
9. Standard configuration of this series has magnet and the type without magnet is not available.

Specification

Bore size(mm)	6	10	16	20	25	32
Acting type	Double acting					
Fluid	Air(to be filtered by 40μm filter element)					
Operating pressure	0.15~1.0MPa(22~145psi)					
Proof pressure	1.5MPa(215psi)					
Temperature °C	-20~70					
Speed range mm/s	30~500					
Adjustable stroke mm	-5~0					
Stroke tolerance	≤100 $^{+1.0}_0$ >100 $^{+1.5}_0$					
Cushion type	Bumper					
Non-rotating tolerance [Note1]	±0.2°	±0.15°				±0.1°
Port size [Note2]	M5×0.8				1/8"	

[Note1] Retract position.

[Note2] G thread is available.

Add) Refer to P519 for detail of sensor switch.

Stroke

Bore size (mm)	Standard stroke (mm)	Max.std stroke
6	10 20 30 40 50	50
10	10 20 30 40 50 60 70 80 90 100	100
16	10 20 30 40 50 60 70 80 90 100 125 150 175 200	200
20	10 20 30 40 50 60 70 80 90 100 125 150 175 200	200
25	10 20 30 40 50 60 70 80 90 100 125 150 175 200	200
32	10 20 30 40 50 60 70 80 90 100 125 150 175 200	200

[Note] When the stroke less then or equal to 100mm, The dimensions of non-std stroke cylinder has the same dimensions as the next longer stroke std. stroke cylinder. e.g. 35mm stroke cylinder has the same dimensions of 40 std. stroke cylinder.

Ordering code

TR 20×50 S G



① Model	② Bore size	③ Stroke	④ Magnet [Note1]	⑤ Thread type [Note 2]
TR: Twin-rod cylinder (Double acting type)	6 10 16 20 25 32	Refer to stroke table for details	S: With magnet	G: G

[Note1] TR Series are all with magnet. [Note2] When the thread is standard, the code is blank.

Inner structure and material of major parts

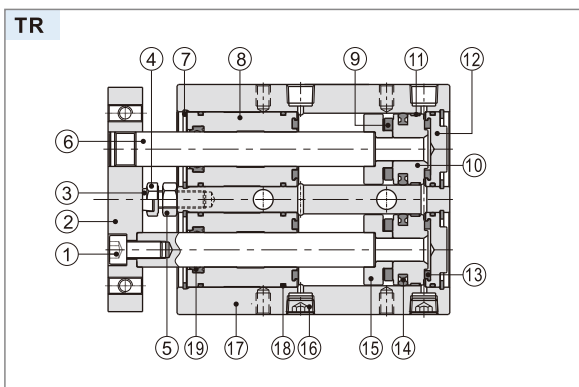

NO.	Item	Material	NO.	Item	Material
1	Screw	Carbon steel	10	Piston	Φ6,10 SUS304
2	Fixing plate	Aluminum alloy		Other	Aluminum alloy
3	Bumper	POM	11	Wear ring	Nylon 6
4	Screw	Free cutting steel	12	Back cover	Aluminum alloy
5	Nut	Carbon steel	13	Bumper	TPU
6	Piston rod	Φ25,32 Carbon steel	14	Piston seal	NBR
	Other	SUS304	15	Magnet holder	Φ6,10 SUS304
7	C clip	Spring steel		Other	Aluminum alloy
8	Front cover	Aluminum alloy	16	Screw	Carbon steel
9	Magnet	Φ32 Plastic	17	Body	Aluminum alloy
	Other	Sintered metal (Neodymium-iron-boron)	18	Back cover O-ring	NBR
			19	Wiper seal	NBR

Twin-rod cylinder

TR Series

Dimensions

TR6~16

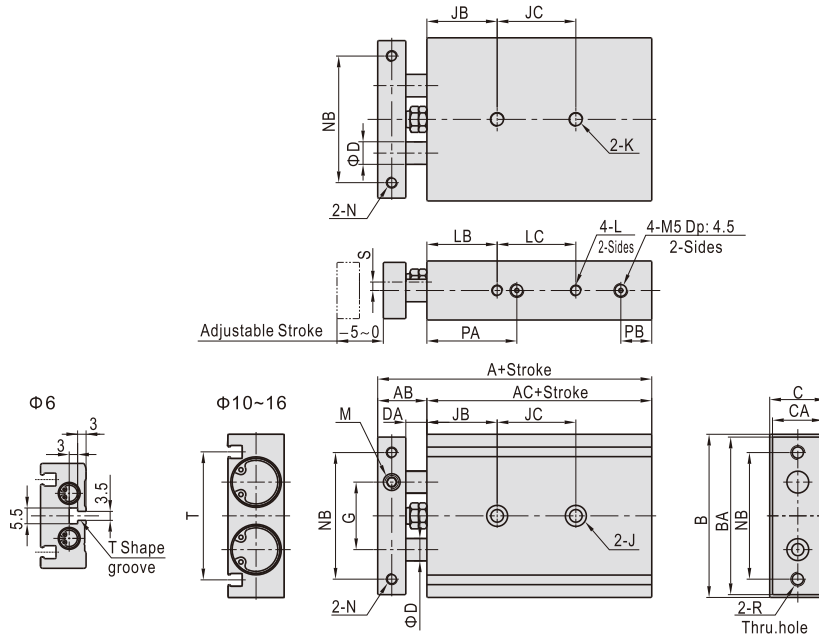

Bore size\Item Stroke	A	AB	AC	B	BA	C	CA	D	DA	G	JC LC						T		
											10~25	30~50	60~80	90~100	125	150		175	200
6	58.5	13.5	45	37	35	16	14	4	8	16	$JC=10+Stroke/2$ $LC=13+Stroke$						23		
10	72	17	55	46	44	17	15	6	9	20	30	40	50	60	-	-	-	36.5	
16	79	19	60	58	56	20	18	8	9	25	25	35	45	55	65	75	145	145	46.5

Bore size\Item Stroke	J			JB	K	L	LB	M	N	NB	PA	PB	R	S
	A	AB	AC											
6	One side: $\phi 6.5Dp:3.5$ Thru.hole: $\phi 3.5$			13	-	$M3 \times 0.5Dp:4.5$	10	$M3 \times 0.5$	$M3 \times 0.5$ Thru.hole	28	24.5	6.5	$M3 \times 0.5$	4.5
10	One side: $\phi 6.5Dp:3.5$ Thru.hole: $\phi 3.5$			20	$M4 \times 0.7Dp:7$	$M3 \times 0.5Dp:5$	20	$M5 \times 0.8$	$M3 \times 0.5Dp:7.5$	35	30	8	$M4 \times 0.7$	3.5
16	One side: $\phi 8.0Dp:4.5$ Thru.hole: $\phi 4.5$			30	$M5 \times 0.8Dp:8$	$M4 \times 0.7Dp:5$	30	$M6 \times 1.0$	$M4 \times 0.7$ Thru.hole	45	38	8	$M5 \times 0.8$	5

TR20~32

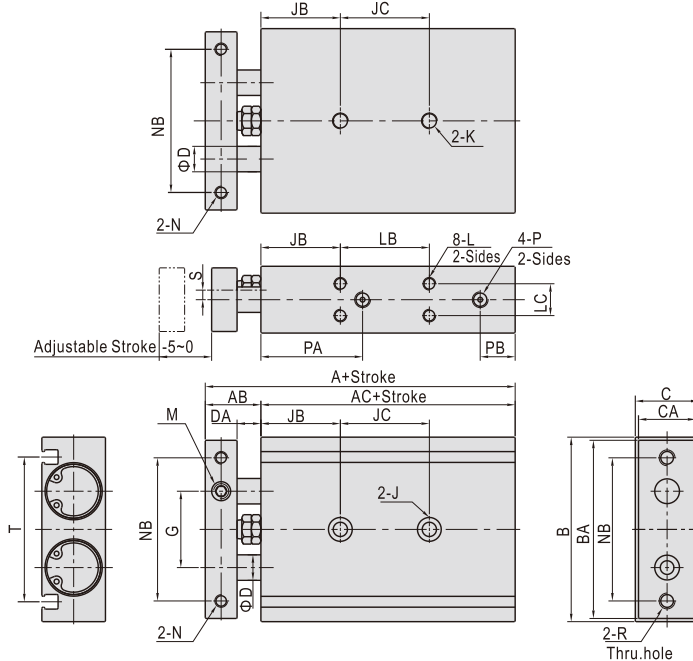

Bore size\Item Stroke	A	AB	AC	B	BA	C	CA	D	DA	G	JB	JC LB						P	PA	PB	
												10~25	30~50	60~100	125	150	175				200
20	94	24	70	64	62	25	23	10	12	28	30	30	40	60	80	80	100	100	$M5 \times 0.8$	46	9
25	96	24	72	80	78	30	28	12	12	35	30	30	40	60	80	80	100	100	1/8"	43	9
32	112	30	82	98	96	38	36	16	14	44	30	40	50	70	90	90	110	110	1/8"	53	10

Bore size\Item Stroke	J			K	L	LC	M	N	NB	R	S	T
	A	AB	AC									
20	One side: $\phi 9.5Dp:5.5$ Thru.hole: $\phi 5.5$			$M6 \times 1.0$	$M4 \times 0.7Dp:5.5$	9.5	$M8 \times 1.25$	$M4 \times 0.7Dp:6$	50	$M5 \times 0.8$	6.5	52
25	One side: $\phi 11Dp:6.5$ Thru.hole: $\phi 7$			$M8 \times 1.25$	$M5 \times 0.8Dp:7$	13	$M8 \times 1.25$	$M5 \times 0.8Dp:7.5$	60	$M6 \times 1.0$	9	61
32	One side: $\phi 11Dp:6.5$ Thru.hole: $\phi 7$			$M8 \times 1.25$	$M5 \times 0.8Dp:7$	20	$M10 \times 1.5$	$M5 \times 0.8Dp:8$	75	$M6 \times 1.0$	11.5	73



Installation and application

1 How to mount workpiece

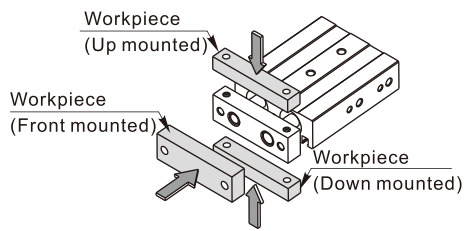

How to mount the workpiece

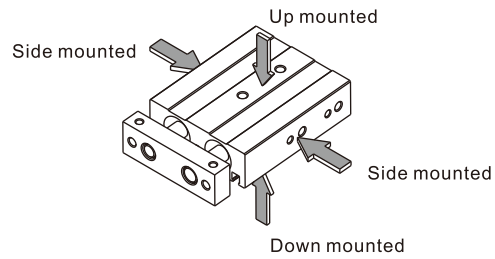

How to mount the cylinder

2 Max. weight of allowable side-load

Mounting type

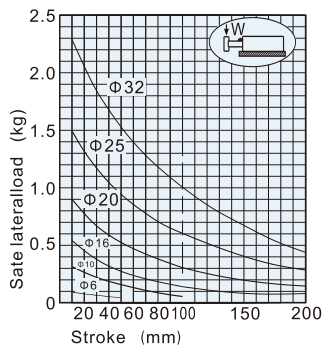
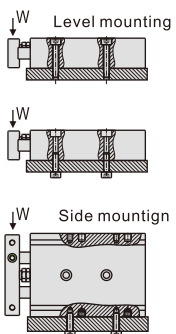

3 Safe deflection

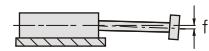
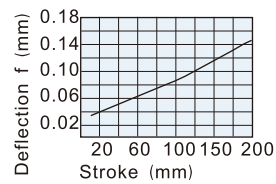

The average value of deflection of rod end of the whole series basically stays in the line showed in the chart on the right.